

THIS MONTH: INFRASTRUCTURE CORROSION

MIP MATERIALS PERFORMANCE

JANUARY 2008

CORROSION PREVENTION AND CONTROL WORLDWIDE

Corrosion of a Marine Bridge-Tunnel *Cathodic Protection to the Rescue*

**Anode Selection for a
Ductile Water Main**

**Cathodic Protection of
Historic Steel-Framed Buildings**

**Optimizing Blast Parameters
to Achieve High Yields**

 **NACE**
INTERNATIONAL

Jackets Wrap Bridge Piles with Cathodic Protection

KATHY RIGGS LARSEN, STAFF WRITER

When it first opened in April 1964, the Lucius J. Kellam Jr. Bridge-Tunnel, also known as the Chesapeake Bay Bridge-Tunnel, was considered an engineering marvel for its time. Named “One of the Seven Engineering Wonders

of the Modern World” in the mid-1960s, the structure’s combination of bridges and tunnels carries U.S. Highway 13 across the mouth of the Chesapeake Bay and one of the country’s busiest shipping channels to link the Delmarva Peninsula to the southeastern portion of the Virginia mainland near Norfolk.

With a total length of 23 miles (37 km) and a shore-to-shore length of 17 miles (27.4 km), the bridge-tunnel features 12 miles (19.3 km) of low-level trestle; two one-mile (1.6-km) tunnels; two bridges; two miles (3.2 km) of causeway; four man-made islands, approximately 5.25 acres each with an elevation of 30 ft (9 m) above the water; and 5.5 miles (8.8 km) of approach roads. Built and operated by the Chesapeake Bay Bridge and Tunnel District, a political subdivision of the



The Chesapeake Bay Bridge-Tunnel is a total of 23 miles long and connects the Delmarva Peninsula to the Norfolk/Virginia Beach area. Photo courtesy of the Chesapeake Bay Bridge and Tunnel District.

Commonwealth of Virginia, the bridge-tunnel is one of only two structures that cross the Chesapeake Bay and, according to the Bridge-Tunnel Commission, is the world's largest bridge-tunnel complex.

Over the years, the reinforcing steel encased within the structure's support piles was exposed to chlorides from the marine environment, and corrosion of the reinforcing steel caused the concrete bridge piles to crack and spall. Although these cracks and spalls were patched and repaired, continued corrosion of the reinforcing steel in some of the bridge's oldest piles prompted the Bridge-Tunnel Commission to install galvanic cathodic protection (CP) jackets to protect these piles from further corrosion.

Anatomy of a Bridge Pile

According to Robert E. Johnson, Director of Maintenance for the Chesapeake Bay Bridge and Tunnel District (Cape Charles, Virginia), the structure is supported with 5,189 concrete Raymond (cylinder) piles. Each pile supporting the bridge is constructed of 16-ft (4.9-m) sections of hollow concrete cylinders, with a 54-in. (1.37-m) outside diameter and a wall thickness of 5 in. (127 mm), that are strung together with 12 to 16 steel prestressing tendons (each tendon consists of 12 individual straight steel wires) running vertically through the walls of the sections, says Chad Saunders, chief engineer for Bayshore Concrete Products Corp. (Cape Charles, Virginia), the company that manufactures the cylinder

piles. He notes that the cylinder piles for the Chesapeake Bay Bridge-Tunnel are comprised of centrifugally spun concrete that is extremely dense with low permeability, and the walls of each concrete section are reinforced with 0.25-in. (6.3-mm) diameter ASTM A82 smooth steel wire that spirals around the circumference of the cylinder at a 4-in. (100-mm) pitch.

When the piles were assembled, the concrete section joints were sealed with epoxy resin, and wire tendons were pulled through each tendon hole previously cast in the concrete sections. Each tendon was stressed to an approximate force of 62,000 lb (28,061 kg). Once the joint epoxy cured, grout was pumped into the tendon holes to surround the prestressing strands. When the grout in the tendon holes cured, the strands were released. The piles, ranging in length from 140 to 180 ft (42.6 to 54.8 m), were driven between 80 to 150 ft (24.3 to 45.7 m) into the bottom of the bay, depending on the resistance of the sand where the pile is located, says Johnson. As the piles were forced into the sea floor, sea bed material filled the void in the center of the piles.

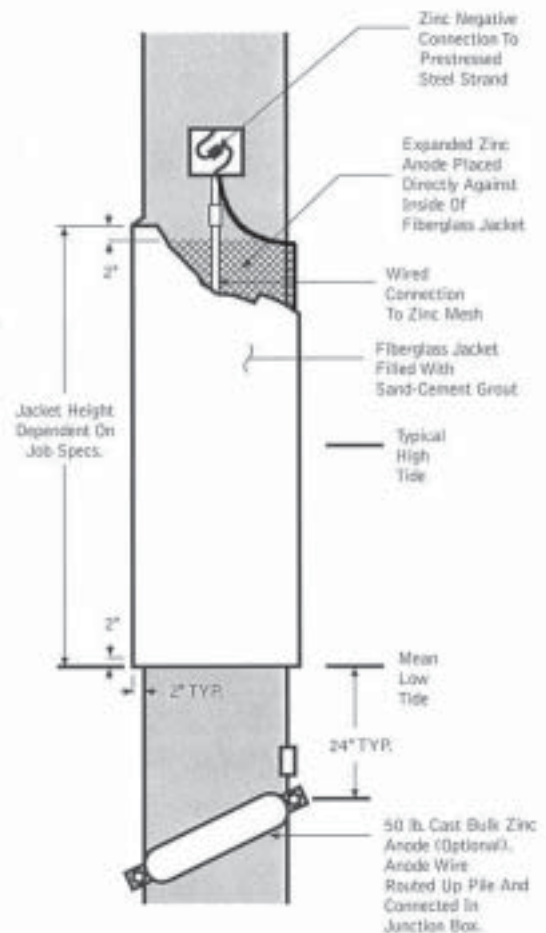

Schematic of a typical CP jacket. Image courtesy of Jarden Zinc Products.

In 1961, when the first section of the bridge was constructed and initial piles were installed, construction crews used a floating barge and a crane to drive the Raymond piles into the bay floor. (Current construction practices utilize a jack-up barge that has the ability to stand above the water with the support of three or four columns that are moved down to the sea bed using a hydraulic system.) As the piles were driven, the hammer did not

Raymond Pile Cross Section

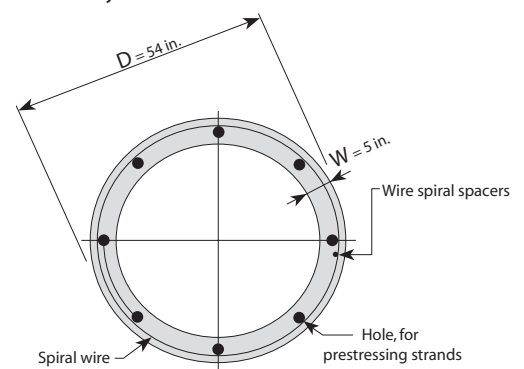

Source: Bayshore Concrete Products Corp.



Each piece of reinforcing steel in the pile section is brazed to a lead wire and connected to a junction box on the pile cap. Photo courtesy of Precon Construction Co.



Installers fill the CP jacket with cementitious material to form a single monolithic fill about 2 in. thick. Photo courtesy of Douglas Leng, Corrosion Restoration Technologies.

hit the piles squarely, which caused hairline fractures in the top of the concrete. At the time, those involved with building the bridge didn't anticipate that the fractures would cause problems. As construction continued, improvements were made to the process of driving piles and newer sections of the bridge didn't experience installation damage to the piles.

During assessments in 1989, inspectors noticed that the reinforcing steel

in the piles with installation fractures was corroding and expanding to the point where it caused the concrete to crack and spall. Fracture repairs were made using epoxy crack injection. This method, a standard practice at the time, was expected to seal the cracks and provide structural strength. However, Johnson explains, because of limitations in the nature of the epoxy material, the steel reinforcements were not adequately

protected from chloride exposure, and the steel continued to deteriorate. Inspections of the bridge's oldest piles in 2000 revealed that cracks were again forming and growing due to the degradation of the reinforcing steel, and chloride levels in the fissures were high. Corrosion damage was generally located right above the water line and is believed to be a result of the hairline fractures that occurred during initial installation.

"It does not require a large amount of chlorides to cause a problem; the general rule is $\geq 0.2\%$ by weight," says Mike Mather, NACE International member, NACE CP Technician, and manager of Sales Engineering for Jarden Zinc Products (Greeneville, Tennessee), manufacturer of CP jackets being installed on selected bridge-tunnel piles. "Typically, it takes a long time—years or decades—for the chlorides from the salt to reach the steel. Chlorides break down the protective layer on the steel, and corrosion starts. When these reinforcing steel elements do corrode, the corrosion by-products (generically known as 'rust') occupy as much as 6 to 10 times the volume of the steel consumed. This creates expansive or tensile forces on the concrete cover, which causes cracking and accelerates the rate of corrosion. This leads to heavy cracking and spalling."

Galvanic Cathodic Protection

In order to combat the corrosion problems and alleviate the cracking and spalling of the concrete piles, the Bridge-Tunnel Commission turned to CP. Although 623 bridge piles require some type of repair, the Bridge-Tunnel Commission determined that piles exhibiting significant cracking (cracks wider than 1/16 in. [1.5 mm]) will be outfitted with fiberglass CP jackets, Johnson explains. Piles with cracks smaller than 1/16 in. wide will be repaired by routing out the cracks and packing them with cementitious material. Any spalls on the piles will be patched with cementitious material as well.

"In order to get an effective repair, it is important to address the root cause of the problem," says Mather. "Since the crack-

ing and spalling is a corrosion problem, CP is the best way to control it.”

The CP jacket system is being installed on 215 of the structure’s piles. Not only does the jacket utilize galvanic CP to mitigate corrosion of the piles’ reinforcing steel, but it also creates a barrier against chlorides, moisture, and oxygen, explains Mather. To form the galvanic cell, the pile’s reinforcing steel is accessed and cathode lead wires from the steel are routed to a junction box bolted on the pile cap. The anode lead wires are also routed to the junction box as the jacket is being installed. “The majority of the anode material, about 600 lb (272 kg) of zinc, is inside the jacket,” Mather adds.

Work started in May 2007, and crews from Precon Construction Co. (Chesapeake, Virginia) are performing repairs and installing the CP jackets using a jack-up barge underneath the bridge deck. When installing a CP jacket, the first step is to connect every piece of steel in the concrete sections to the pile’s CP system, says Douglas Leng, director of Business Development for Corrosion Restoration Technologies (Tequesta, Florida), NACE member and chairman of Nace Task Group 047, “Reinforced Concrete: Sacrificial Cathodic Protection of Reinforced Concrete Elements,” and technical contact for the project. Leng is also a co-inventor of the Lifejacket® CP jacket system.

To do this, installers drill from the face of the pile into the concrete to expose a portion of the reinforcing steel, including the spiral wire and each prestressing strand, and then braze an American Wire Gauge (AWG) no. 10 copper wire onto the steel. Epoxy is applied at the connection point and the drill hole is plugged with grout material. “The piles have a unique reinforcement configuration because the reinforcing spiral wire in each segment is independent rather than continuous. So the spiral wire in each pile segment under the jacket must be connected,” Leng says. “Consequently, we use as many as 60 wires per pile for a single jacket system to ensure that all the steel is protected.”



Bridge piles with installed galvanic CP jackets. Photo courtesy of Douglas Leng, Corrosion Restoration Technologies.

Each fiberglass jacket is installed in four sections, and grout comprised of Portland cement and sand is pumped from the bottom of the jacket to the top from alternate pumping ports to create a single monolithic fill about 2 in. (51 mm) thick. The CP jackets, some of the largest the company has ever fabricated, were designed to withstand the high waves and swells resulting from the harsh Atlantic Ocean weather as well as maritime activities in the nearby shipping lanes. The jackets extend about 2 ft (0.6 m) below the mean low tide line up to ~ 1 ft (0.3 m) below the pile cap, for a total length of about 23 ft (7 m) with an inside diameter of 58 in. (147 cm).

“Because the fractures occurred when the piles were initially driven, most of the cracks appear at the top of the piles, and a good number have propagated closer to the water line,” says Mather.

Once the cement fill is cured, lead wires from the reinforcing steel in the pile and the zinc anode (mesh in the jacket and bulk anodes in the water) are connected in the junction box. The existing concrete and the concrete fill in the jacket work together to form a common electrolyte. “Initially we see a fairly high delivered current flow of several hundred

milliamps. As the current flows over time, the steel polarizes,” says Mather. “Within a period of weeks or months, the amount of current required to maintain polarization drops to 1 mA/ft² or less,” he adds. “The system is designed to protect the piles for 25 or more years.” Mather explains that the system current will self adjust to meet changes in temperature, humidity, concrete resistivity, and other factors, and it exceeds the 100 mV polarization shift criterion set by NACE CP standards.

Two 48-lb (21.7 kg) bulk zinc anodes are bolted to the bottom of each jacketed pile and connected to the pile’s CP system to provide extra protection to the submerged portion of the pile and prevent current dump-off from the lower region of the jacket, Leng adds.

The cost to install the CP jackets and make other repairs to the piles is estimated at \$12.5 million and work is expected to be completed in early 2009. Since all work will be performed from the water, no traffic delays are expected to occur. The bridge-tunnel operation is wholly funded by revenues from tolls. In 2006, about 3.62 million vehicles paid a toll and generated over \$47.9 million, says Johnson. **MP**